



Model 0

Single leverage Arbor Press

Instruction and Parts list

<u>Item</u>	<u>Part Name</u>	<u>Part Number</u>
1	Handle	128
2	Retaining ring (National lock washer number XRC-327)	43965
3	3/8"-16 x 3/4" thumb screw	43622
4	Spindle	129
5	Retaining ring	67424
6	Ram (1" x 1" x 12")	127
7	3/8"-16 x 5/8" headless set screw	43589
8	Brake spring	108
9	Tinners rivet	43577
10	Ram cap	122
11	5/16"-18 x 1" hex cap screw	43315
12	Ram cap shims (.008")	125
13	Ram cap shims (.015")	126
14 & 15	Table Plate assembly	700806
16	Frame	117

Please contact factory for current prices.

Ordering information: Please order all repair parts by part number and name, also mention model number of press. All parts are shipped F.O.B. Factory in Grand Haven, MI.

Lubrication: Keep all working parts of the press well oiled for easier operation. Also keep a light film of oil over the entire surface of the ram to prevent rust.

DAKE

Division of JSJ Corp.
724 Robbins Road
Grand Haven, MI 49417

Phone: 616-842-7110 800-937-3253
Fax: 616-842-0859 800-846-3253
E-Mail: customerservice@dakecorp.com
technicalservice@dakecorp.com
Website: www.dakecorp.com

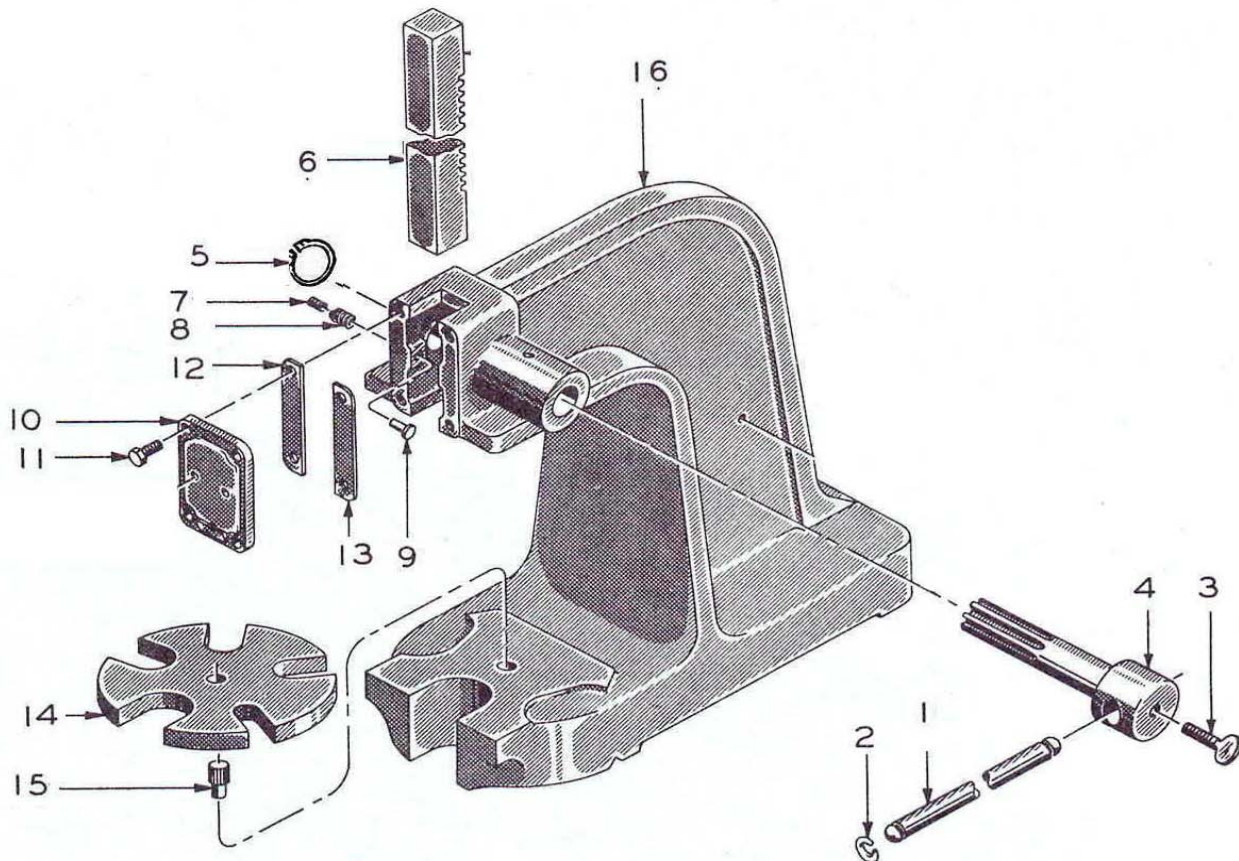

SAFETY

This is the safety alert symbol. When you see this symbol on your press, be alert to the potential for personal injury.

Follow recommended precautions and safe operating practices.

Carefully read all safety messages in these instructions and on your press safety signs. Keep safety labels in good condition. Replace missing or damaged safety labels.

This machine is intended to be operated by one person. This person should be conscious of the press ram movement not only for themselves but also for persons in the immediate area of the machine.

Under no circumstances increase the leverage ratio of the press by using a longer handle or by placing a pipe over the handle. Never hammer on top of the ram.